

2010
37th District Report



Prepared by

Congresswoman
Laura Richardson

CALIFORNIA 37TH CONGRESSIONAL REPORT
Prepared by
CONGRESSWOMAN LAURA RICHARDSON

I. ABOUT CONGRESSWOMAN

**LAURA RICHARDSON, THE STAFF, AND
THE 37TH DISTRICT**

- Biography of Congresswoman Laura Richardson
- About the District
- Office Locations and Hours of Operation
- Staff Directory

II. DISTRICT REPRESENTATION

- Satellite Offices
- Casework
- Updated Congressional Website
- Launch of The People's Congress
- Other Constituent Services

III. MEMBER ACHIEVEMENTS

- Committee Assignments
- Voting Record
- Appropriations
- Hearings (Washington D.C. and in the Field)
- Conference Reports
- Recovery Act
- SAFETEA-LU

IV. LEGISLATION

- Legislation Introduced
- Legislation Pending
- Major Votes Cast in The 111th Congress

V. DELIVERABLES TO THE DISTRICT

- Meetings and Events
- Telephone Town Halls
- Annual Senior Briefing
- Congressional Art Competition
- In the Community

VI. NEXT STEPS

- Legislation
- Major Policy Progress
- Continuing to Increase Visibility
- Sub-Committee Chair – Emergency Communications, Preparedness, and Response
- Additional Funding
- Open Watts/Willowbrook Satellite Office

CONGRESSWOMAN LAURA RICHARDSON



CALIFORNIA'S 37TH DISTRICT

Congresswoman Laura Richardson's path to the nation's Capitol is often described as an "American" story. Ms. Richardson's maternal great-grandparents were opportunity bound immigrants from Ireland and Germany; her fraternal great-grandparents came by way of slavery and bondage. Both families found their way to Schenectady, New York ---- where Laura Richardson's parents were born.

Given that Congresswoman Richardson's mother is Caucasian and her father African American; both were disowned in the 1950's by their families for their marriage. This led to Ms. Richardson's father joining the Army and later, her family moving to California.

With the nation's racial turmoil in the 60's, Congresswoman Richardson's parents divorced when she was only two years old. Based on these challenging personal family experiences and witnessing the civil rights movement, at the age of six, Congresswoman Richardson decided her first choice of profession would be public service. Working since the age of 12, hard work and limited resources was the only life Ms. Richardson knew.



After trying out for women's basketball team in the 1980 Olympics, graduating from the University of California, Los Angeles (UCLA), with a degree in Political Science, working 14 years in the private sector at Xerox Corporation and then receiving her Masters in Business Administration from the University of Southern California (USC), Laura Richardson reaffirmed her desire to use her skills to help others.

In 2000, Ms. Richardson joined the Long Beach City Council where she served the fifth largest city in the State of California. Relying on her educational background, Ms. Richardson uncovered a two decade old, \$100 million plus budget deficit, established fiscal policies, chaired the first-ever Budget Oversight Committee and delivered over \$40 million dollars of development in traditionally underserved communities.

In 2006, Laura Richardson won a seat in the State Legislature where she immediately stepped into the Assistant Speaker Pro Tem leadership position. She was recognized as the first South Bay representative, freshman, and African-American woman to hold this prestigious role. Additionally, Ms. Richardson earned the much coveted committee assignments of Transportation and Infrastructure, Health and Human Services and Government Organization (alcohol, tobacco and gaming).

In 2007, after six short months in the Assembly, Laura Richardson went on to succeed 16 candidates in a special election and was elected to her first term in the United States House of Representatives to represent California's culturally and economically diverse 37th Congressional District. She is currently a member of the House Committees on Transportation & Infrastructure and Homeland Security and in January, after less than two and a half years in office, was named the Chair of the Homeland Security Subcommittee on Emergency Communications, Preparedness, Response, which as part of its responsibilities has oversight over FEMA and many public safety grants.

Congresswoman Richardson set a record of distinction in having served all three levels of government; local, state and federal all in the span of less than one year. As noted in the Los Angeles Sentinel newspaper, Laura Richardson's "meteoric rise" has been nothing short of amazing.

California's 37th Congressional District

California's 37th Congressional District is one of the most diverse districts in the United States. Home to varying groups of Hispanics, African-Americans, Caucasians, and the world's second largest grouping of ethnic Cambodians and Samoans. The 37th Congressional District is rich with cultural, ethnic, and economic benefits and challenges. Located adjacent to the Port of Long Beach, the District is a global hub of intermodal transportation and goods movement, with nearly 45% of all U.S. imports traveling through its neighborhoods.

The 37th Congressional district's yearly median income is \$34,006, which is significantly lower than neighboring districts, CA-36 and CA-46, at \$51,633 and \$61,567 respectively.

Poverty and Unemployment

This economically diverse District faces a number of difficulties associated with high levels of urban poverty and unemployment. In 2007, the U.S. Census Bureau estimated that 21 percent of individuals and 18% of families in the 37th District lived in poverty. However, the current economic recession has more than likely increased these statistics. Because of this endemic poverty District's education system cannot offer the same level of after-school, tutoring and job training programs offered in many neighboring communities. This means fewer students attain a full high school education, undergraduate education, or even meaningful employment.

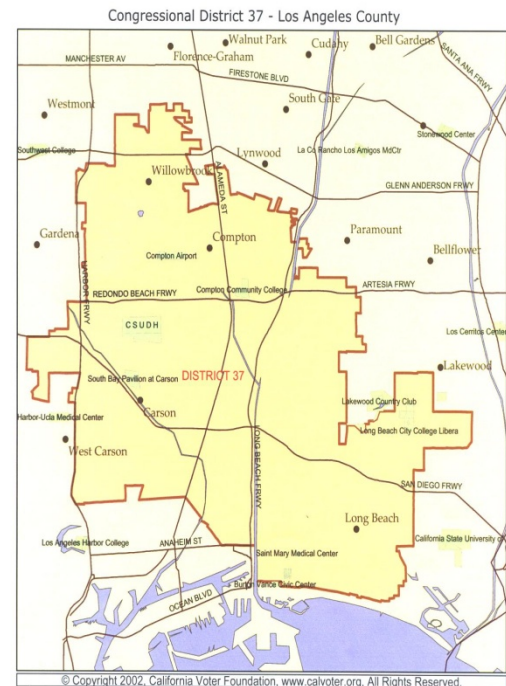

37th District Unemployment

Carson	12.4%
Compton	20.6%
Long Beach	13.5%
Signal Hill	9.8%

What's Good About The District

Although the district faces a high rate of poverty and unemployment, the workforce represents valuable asset. The diversity of the district's population mirrors the diverse nature of the workforce, which includes many that are educated, well trained and experienced.

Educational services are a major component. Over 25,000 district residents are employed within this sector of the economy that includes three universities and two community colleges. The district includes students, teachers and staff from California State University Long Beach and California State University Dominguez Hills, which has the highest enrollment of all the schools in the Cal State system. The District includes four school districts Compton, Long Beach and Los Angeles Unified School District. Long Beach Unified School District includes two of the highest rated high schools in the state. The district has been a winner and runner up for the prestigious Broad Award for the best urban school district in the country.

Medical services are another important sector for the area workforce employing close to 25,000 persons. The five major medical facilities include Long Beach Community Hospital, St. Mary's Medical Center, Pacific Hospital, Long Beach Memorial Medical Center with the recently constructed Miller Children's Hospital. Martin Luther King hospital is being reborn as a state of the art hospital and medical complex.

Manufacturing and aircraft production employ over 30,000 area residents. Boeing Aircraft in Long Beach produces the premiere military air transport plane in the world, the C-17.



Over 18,000 area residents are employed in the field of transportation and warehousing. The 37th district includes the Port of Long Beach, which competes annually with its neighbor the Port of Los Angeles for the title "America's largest port".

Other major occupations involving the district workforce are travel, tourism, trade, finance, insurance, arts, entertainment and management services. The district faces both challenges and opportunities. In order to provide direct services through our satellite offices, desperately needed resources and relevant legislation, requires a knowledgeable, committed and highly skilled staff in the District and in Washington, D.C. offices.

Office Locations & Hours

Providing constituent services is a top priority for Congresswoman Richardson and her district staff. In understanding that many residents are not able to travel to the Long Beach office, for the first time in the history of the 37th Congressional District, the Congresswoman and her staff operate satellite offices in all of the cities in the district to better accommodate the less mobile in our district.

Main Office – Long Beach

100 W. Broadway
West Tower, Suite 600
Long Beach, CA 90802
(562) 436-3828
Monday - Friday
9:00 a.m. to 6:00 p.m.

Compton/Watts Office

Located In: Compton City Hall

205 S Willowbrook Ave
Compton, CA 90220
Tuesday 9:00am-2:00pm
Thursday 1:00pm-6:00pm

Carson Office

Located In: Carson City Hall

701 E Carson St
Carson, CA 90745
Tuesday 1:00pm-6:00pm
Thursday 10:00 a.m.- 2:00 p.m.

Signal Hill Office

Located In: Signal Hill City Hall

2175 Cherry Ave
Signal Hill, CA 90755
Friday 9:00 a.m. – 4:30 p.m.

Washington, DC – Capitol Office

1725 Longworth House Office
Washington, DC 20515
(202) 225-7924
Monday - Friday
9:00 a.m. to 6:00 p.m.

37th Congressional District Organizational Chart

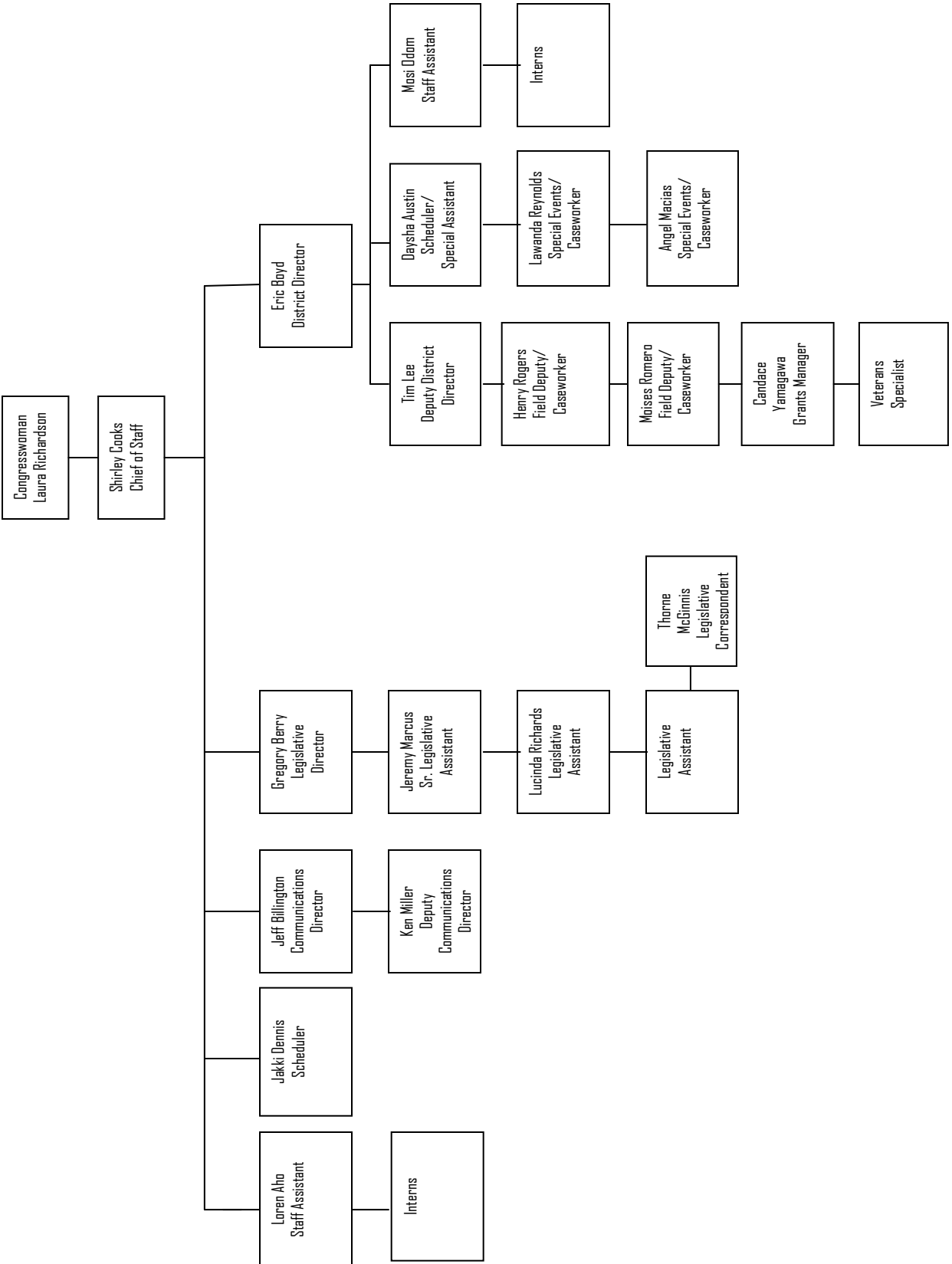

Staff Directory

Congresswoman Laura Richardson Staff Biographies

WASHINGTON, DC OFFICE

Shirley Cooks

Chief of Staff

Shirley has worked in Congress since January 2001, working for Congresswoman Juanita Millender-McDonald and Congressman Steve Cohen before coming to the office of Congresswoman Laura Richardson. Previous to coming to the Hill, Shirley worked as the Deputy Assistant Secretary of State for Legislative Affairs under Secretary Madeleine Albright. Shirley's responsibilities as Chief of Staff range from assisting the Member with legislative, policy and political decisions to helping shape the Congresswoman's schedule to oversight of all DC and District staff.

Gregory Berry

Legislative Director

Gregory is Congresswoman Richardson's Legislative Counsel, serving as principle adviser on foreign affairs, homeland and national security, and judiciary issues. Before coming to Capitol Hill, Greg was a member of the faculty at the Howard University School of Law for eight years. He received his J.D. from the University of Pennsylvania Law School. He also holds an M.A. in Political Science from the University of Michigan and a B.A. in Business Administration from the University of Washington's School of Business.

Jeff Billington

Communications Director

Jeff has served as Congresswoman Richardson's Communications Director since September 2009. In this position he serves as her chief communications and press officer, managing all aspects of the office's media and communications operations. Before joining the Congresswoman's staff, he worked for four years as the primary media and communications staff member for the National Legal Aid & Defender Association and prior to that he served in various communications and publications roles at state and national nonprofits. He has a BA in Mass Communications from Missouri Southern State University.

Jeremy Marcus

Senior Legislative Assistant

Jeremy has worked in Congress since 2007 and for the government since 2004, working for Senators Kerry and Rockefeller and for the International Trade Administration, The Technology Administration, and NASA. Jeremy received his Bachelors and Masters in California at Stanford University. Jeremy's responsibilities include handling the transportation, infrastructure, energy, trade, small business, and telecommunications portfolios for Congresswoman Richardson.

Lucinda Richard

Legislative Assistant

Lucinda has always had a career of public service, whether it was through teaching first grade in Oakland or investigating civilian complaints of police misconduct in New York. Lucinda joined the Congresswoman's Washington, DC office in September 2009. She handles a variety of issues including health care, education, Coast Guard and maritime transportation, youth & children, social security, and Hispanic affairs.

Thorne Maginnis

Legislative Correspondent

Thorne has served on Congresswoman Richardson's staff since January 2010, before which time he worked as an intern in the office of Congressman Charlie Melancon of Louisiana. Prior to his time on Capitol Hill, Thorne was as a public policy fellow at KSCW, Inc., a government affairs group in Washington, DC. In Congresswoman Richardson's office, Thorne is responsible for all constituent correspondence and letter drafting, as well as legislative issues concerning senior citizens.

Jakki Dennis

Scheduler

Jacquelin Dennis joined Congresswoman Richardson's office on June 21, 2010 as Scheduler. Most recently, she served as a group facilitator with adults confronting their mental illness and committed to improving their quality life. Prior to this experience, she produced events and raised millions of dollars in scholarships for the Congressional Black Caucus (CBC) Spouses Scholarship Programs. Politically, Jakki has worked for Presidents Carter, Clinton and an Inaugural event for President Obama. She also worked for Presidential hopefuls Walter Mondale as a Press Advance Lead and Sen. John Glenn as Campaign Scheduler.

Loren Aho

Staff Assistant

Loren has worked in Congress since June 2007, working for Congressman Bart Stupak before coming to the office of Congresswoman Laura Richardson. Loren has a Bachelor Degree in Business Management and a Master's Degree in Public Administration both through Northern Michigan University. Prior to coming to the Hill, Loren was the coordinator for an after-school and summer program for kindergarten through 8th grade students in five school districts. Loren also previously was the governmental affairs chairperson for the Michigan Head Start Association.

CALIFORNIA DISTRICT OFFICE

Eric F. Boyd

District Director

Eric is the chief staff officer in the district office. He supervises all district office staff, oversees all district office and satellite office functions and serves as the lead staff liaison to the new 37th Congressional District People's Congress. Eric was a former District Director (2004- January 2009) in the CA State Senate and State Assembly for current LA County Supervisor Mark Ridley-Thomas. Eric also represents Congresswoman Richardson on the Greater LA and Carson African American Chambers of Commerce and South Bay Cities Council of Governments. Eric is a resident of the 37th Congressional district, living in Carson.

Tim Lee

Deputy District Director

Tim serves as Deputy Director of the district office. He supervises field staff and field operations and is the primary staff liaison for proclamations, resolutions, and other Congressional recognition vehicles for the community. Tim was a professional staff member in Congresswoman Richardson's City Council and State Assembly Offices. Tim is a resident of the 37th Congressional district, living in Long Beach.

Daysha Austin

Scheduler/Special Events Coordinator

Daysha is the Scheduler for the Congresswoman's district activities, serves as Office Manager and primary Special Events coordinator. She is also the lead staff responsible for coordinating and planning all 37th Congressional District special events and projects. Daysha often represents the Congresswoman at local women's groups, and has been with Congresswoman Richardson for her entire elected career. Daysha is a resident of the 37th Congressional district, living in Long Beach.

Henry Rogers

Field Representative/Caseworker

Henry serves as staff liaison to the city of Signal Hill, and chief staff liaison to the San Pedro Bay Ports. Henry also represents the Congresswoman on a number of local Chambers of Commerce and Councils of Governments. He has worked for the Congresswoman since her days on the Long Beach City Council. He earned his B.A. from San Diego State University and is currently pursuing his M.B.A. from the University of Redland. Henry is a resident of the 37th Congressional district, living in Long Beach.

Moises Romero

Caseworker/Field Representative

Moises works as the primary liaison for veterans and constituents needing Immigration casework. He is also a field representative to Long Beach and Compton, representing the Congresswoman at various community group meetings in those cities. Moises previously worked for Congresswoman Richardson for about one year in the Long Beach City Council.

Candace Yamagawa

Field Representative/Grants Coordinator/Caseworker

Candace has worked for Congresswoman Richardson since August 2009 and previously worked for former state Assembly member, now state Senator, Alan Lowenthal. Prior to joining Congresswoman Richardson's office, Candace assisted non-profit organizations via grants development and conducting fund raising events. Candace's responsibilities as field representative/grants coordinator range from addressing and monitoring District issues, providing grant related technical assistance, conducting constituent casework and staffing the Carson satellite office.

Lawanda Reynolds

Field Representative/Caseworker/Special Events Assistant

Lawanda has worked in Congresswoman Laura Richardson's office since August 17, 2009. Lawanda was previously Congresswoman Richardson's Volunteer Coordinator, as a 37th district constituent volunteer. Prior to her new position in special events, Lawanda was a Student Intervention Specialist for the Long Beach Unified School District for 10 years. Lawanda loves her job, and she especially enjoys working with the seniors throughout the 37th Congressional district.

Angel Macias

Caseworker/Field Representative/Special Events Assistant

Angel currently serves as a part time caseworker for Congresswoman Richardson in her Long Beach Office. In this role she assists people from the community who come to the office seeking aid in dealing with federal agencies. She also works as an independent consultant developing mentoring/youth programs for businesses and nonprofit organizations while also balancing her time as the CEO and Founder of California Families in Focus. Prior to working as an independent consultant, Angel was employed by The Center Long Beach where she served as development director. Prior to that, Angel was administrative aide to Congresswoman Richardson when she sat on the Long Beach City Council.

Ken Miller

Deputy Communications Director

Kenneth has worked for Congresswoman Laura Richardson staff since September 2, 2009. Prior to joining Rep. Richardson, Kenneth worked for the Los Angeles Sentinel Newspaper for 31 years serving in a variety capacities which culminated in his final post as Managing Editor. Kenneth's responsibilities include coordinating media activities within the 37th District and IRS and UPS case work on behalf of constituents.

Mosi Odom

Staff Assistant

Mosi has worked for Congresswoman Richardson since September 2009. Prior to joining Congresswoman Richardson's office Mosi worked as a Legal Secretary and Scheduler at firms in the Los Angeles area. That experience was preceded by employment with the City of Long Beach, where she was an administrative assistant and helped to coordinate volunteers for the city's recreation & marine department. Mosi grew up in Long Beach, and continues to serve her home town via management of District Office administrative/clerical functions, constituent casework, and assisting with the training and supervision of student interns.

37th DISTRICT CASEWORK

	2008	2009	2010
Social Sec.			
Active	0	18	7
Closed	12	39	12
Veterans			
Active	0	55	93
Closed	18	19	13
VISA/Imm			
Active	0	10	31
Closed	11	63	9
Other Services*			
Active	0	21	31
Closed	30	48	48
Total Open	71	273	214
Total Active	0	104	162
Total Closed	71	169	82

*Other Services include Post Office, IRS, Medicare, etc.

SS=51 VA=136 VISA/Imm-93 Others=46

CA 37 DISTRICT CASEWORK SUCCESS STORIES

IRS

Linda came into our District Office in Long Beach in June 2010 requesting help for her sister who had suffered a stroke and was subjected to forced wage garnishments from the IRS. Linda's sister was retired and disabled and living in an assisted living home in Long Beach. The sister was receiving two incomes; One from her County Employees Association retirement, and a smaller amount from her disability.

The IRS threatened garnishing her retirement income which would have made her rent unaffordable. Her ailing health was in jeopardy also. Our office contacted the IRS and explained the condition of Linda's sister and had the garnishment lifted for good within a four week period.

Linda expressed her sincere thanks to our office for helping her sister who is recovering without any interruption of her income, and is receiving the medical services she requires.

SOCIAL SECURITY

Veda visited the 37th District Office in July 2010, when her attorney was not able to get a response from the Social Security Administration regarding an appeal for back wages. Veda had exhausted her unemployment and general relief benefits in addition to her claims for social security, and was unable to work due to a wrist injury she's suffered from for several years.

Within three days the CD-37 Staff was able to secure a Social Security Administration scheduled hearing for Veda. Her appeal will now be heard within 90 days.

CA 37 DISTRICT CASEWORK SUCCESS STORIES

Housing/Loan Modification

Maurice called the District Office of Congresswoman Richardson in a very worried state. His 85 year-old mother lives in her home in Carson, which had been owned by their family for almost 40 years. Maurice and his siblings had been out of the house for many years, and the financial strain of paying their own mortgages and that of their mother was becoming too great.

They contacted their lender – a large national bank – and applied for a Loan Modification through the Federal HAMP program. The process was going smoothly, but took a sudden turn for the worst 6 months into their “Trial Period”. The bank set a foreclosure sale date of May 31, 2010, which was very disconcerting to Maurice’s elderly mother. Maurice contacted our office.

37th District Staff sat with Maurice, reviewed all of his documents, and contacted the Congressional Liaison at his bank’s national corporate headquarters. With the help of Operation Hope, Maurice and the bank first got the sale date postponed to July 31, and later indefinitely. They ultimately got the Loan Modification process back on track, and by the end of July the bank approved Maurice and his mother’s Loan Modification. Maurice’s 85 year old mother now will retain ownership of their family’s home for the foreseeable future.

Veterans

Veteran Howard of Signal Hill, visited Congresswoman Richardson’s Long Beach Office on April 20, 2010 after he had problems with his veterans Administration checks not being properly automatically credited into his bank account. This impacted Howard in paying his bills, purchasing food and buying gas for his automobile.

Congresswoman Richardson’s office quickly reached out to the West Los Angeles Veterans Administration and discovered the bank failed to properly credit his payments to his account. With Congresswoman Richardson’s help, Howard’s case was resolved favorably on July 6, 2010 and his automatic deposits are now being correctly processed on time helping Howard to have an easier time meeting his expenses.

Congresswoman Richardson's New Website

Congresswoman Richardson will launch a new, more technologically advanced website during the second week of September 2010 that will offer site visitors more information and will be easier for them to navigate and use.

The website will work on the Web 2.0 philosophy, meaning it will allow visitors a much more interactive experience, from visiting photo and video galleries to following the Congresswoman through updates there and through Facebook and Twitter.

It will also include information on important federal legislation and policy, including regular updates of Congresswoman Richardson's activities. In addition, it will include links to information about the 37th Congressional district and the resources there and community news and notices.

What the new website will include:

- Information on Congresswoman Richardson's Legislation
- Information on how legislation is submitted
- A Day in the life of Congresswoman Richardson
- Laura's Angels, a section honoring impactful citizens who passed
- Business of the Month, highlighting small businesses in 37th District
- Scholar-Athletes of the Month
- Volunteer of the Month
- Photo Gallery of Congresswoman Richardson and the District
- Video Gallery of Congresswoman Richardson at Work

Congresswoman Richardson's New Website (cont.)

- Links to Federal Programs that can help constituents
- The Latest News, Including News from and About Congresswoman Richardson and the 37th District
- Federal Funds Heading to the 37th District
- About the 37th Congressional District
- How to Contact and Follow Congresswoman Richardson (Including Links to Her Facebook and Twitter Accounts)
- Ways Congresswoman Richardson's Office Can Help You (Such as Dealing with Federal Agencies on Matters Like Social Security, VA, Immigration, IRS and Medicare)
- Programs and Events from Congresswoman Richardson's Office, the Annual 37th District Senior Briefing and the Congressional Arts Contest
- Programs for Youth, the Congressional Page Program and Military Academy Nominations
- Bi-lingual Information and Pages

Congresswoman Richardson's current website is at www.house.gov/richardson and she can be found on Facebook at www.facebook.com/RepLauraRichardson and on Twitter at [RepLRichardson](https://twitter.com/RepLRichardson)

CONSTITUENT SERVICES

Providing outstanding constituent service to the residents of the 37th Congressional District is the number one priority for Congresswoman Richardson's district staff. Most of the constituent casework involves the Departments of Veterans Affairs, Immigration, Social Security, Federal Housing, Internal Revenue Service and United States Postal Service. To date, Congresswoman Richardson's district office has completed 238 constituent cases. Keeping an open and transparent dialog with the residents of the 37th Congressional District is a top priority for Congresswoman Richardson's Washington, DC office. The Capitol office receives letters, faxes, emails and phone calls on a regular basis from constituents wishing to voice their opinion on a wide variety of issues. To date, Congresswoman Richardson's Washington, DC office has responded to over 37,000 constituent correspondences in the forms of letters, faxes, emails and phone calls.

Form of Communication:	Number of Contacts:
Letter	3,534
Email	30,665
Phone Calls	3,315
Fax	2,229

Over the past month, about 50% of the mail has concerned the following subjects:

Issue:	Number of faxes, email, phone calls and letters:
CLEAR Act	103
Final Wall Street Reform	84
DISCLOSE Act	72
War Funding in Supplemental Approps	66
International Violence Against Women	60
Land and Water Conservation Fund	56
Education Jobs Fund in Supplemental	44
Crisis Pregnancy Centers	44
Unemployment Extensions	37
Gaza Flotilla Raid	32
Deepwater Horizon Oil Spill	29
Animal Crush Videos	28

Tour Sites:	Number of Requests:
Flag Request	68
White House	295
Capitol	302
Bureau of Printing and Engraving	292
Library of Congress	288
Supreme Court	196

Congresswoman Laura Richardson

Committee Assignments

Homeland Security

Sub-Committee Assignments:

February 1, 2010: Appointed Chair of Subcommittee on Emergency Communications, Preparedness, and Response

Jurisdiction: **The Chairman has positioned the ECPR subcommittee to examine part of the jurisdiction of Rule X below:** (D) Domestic preparedness for and collective response to terrorism (as well as information sharing).



Within this jurisdictional framework, we are able to examine a number of issues as they relate to the prevention, preparation, response, and recovery from terrorism events.

These issues could include DHS and FEMA management and policy as they relate to homeland security grants (primarily State Homeland Security Grant Program and Urban Areas Security Initiative), urban search and rescue teams, preparedness and response exercises, Integrated Public Alert and Warning System, emergency communications and interoperability and the metropolitan medical response system program, citizen readiness / corps, etc.

Recommends funding for Federal Emergency Management Agency (FEMA). Supports Committee in its oversight responsibility for FEMA and our nation's first responders to better prepare our nation for national emergencies, and to ensure efficient and appropriate response. Grants include: Regional Catastrophic Preparedness Grant Program, the Urban Areas Security Initiative—two vital grant programs aimed at protecting and securing our Nation's highest risk areas; Emergency Management Performance Grants.

In less than one year, Congresswoman Laura Richardson has served as lead on the committee that evaluated the earthquake/tsunami in American Samoa, and the current oil spill in the Gulf region.

Congresswoman Richardson currently is also a member of Intelligence, Information Sharing and Terrorism Risk Assessment.

Major Programs and funding in Homeland Security

DHS's ability to fulfill its mission and secure the United States against all threats through five main action areas:

- Preventing terrorism and enhancing security;
- Securing and managing our borders;
- Enforcing and administering our immigration laws;
- Safeguarding and securing cyberspace; and
- Ensuring resilience to disasters.

Provides funding for: Secret Service, Customs and Border Patrol, Coast Guard, FEMA, U.S. Visitor and Immigrant Status Indicator Technology, Office of Health Affairs, Federal Protective Service, United States Citizenship and Immigration Services.

Grants include: State Homeland Security Grant Program, Citizen Corps program, Emergency Management Performance Grants, Urban Area Security Initiative, Port Security Grants. Long Beach has been awarded a significant amount of funding from the Urban Area Security Initiative Grant Program. It was announced on August 9, 2010 that the city would share a nearly \$55 million grant to improve homeland security.

Committee on Transportation & Infrastructure

Subcommittees: Aviation, Highways and Transit, Coast Guard and Maritime Transportation, and Railroads, Pipelines and Hazardous Materials

- The House Transportation **Subcommittee on Coast Guard and Maritime Transportation**. The Subcommittee has jurisdiction over maritime safety, security, law enforcement, and defense. Additionally, the Subcommittee exercises jurisdiction over merchant marine matters such as ocean shipping and cruise ships. The jurisdiction of this Subcommittee does not extend to matters directly related to national defense, which are handled by the House Armed Services Committee.
- The House Transportation **Subcommittee on Railroads, Pipelines, and Hazardous Materials**. The Subcommittee oversees regulation of railroads, including economic regulations, Amtrak, rail safety, and labor.
- The House Transportation **Subcommittee on Aviation**. The Subcommittee has jurisdiction over civil aviation, including most aspects of the Federal Aviation Administration (FAA), the Transportation Security Administration, and the National Transportation Safety Board.
- The House Transportation **Subcommittee on Highways and Transit**. The Subcommittee oversees the construction of roads and other transit facilities. It has jurisdiction over the U.S. Department of Transportation, and some provisions of the Clean Air Act.



37th District is a Global Hub

California's 37th Congressional District is a global hub of intermodal transportation and goods movement with nearly 45% of all U.S. imports traveling through the District. While the Ports of Long Beach and Los Angeles are economic engines for the 37th District, the detrimental impacts on our infrastructure and environment is alarming. Last year alone, more than 14,200,000 TEUs, Twenty-foot Equivalent containers, traveled over the bridges, roads and rails traversing the 37th. Over 10% of all imported goods travel over the Gerald Desmond Bridge alone, just one of the many bridges in the 37th in urgent need of replacement or repair.



While investments have been made over the years in my area's transportation infrastructure such as the construction of the Alameda Corridor, a 20-mile rail corridor that transports over 8,800 TEUs daily, the transportation infrastructure needs far outstrip the current level of federal investment. The district has been visited by several high level administration officials and Congressional representatives to view the complexity of the transportation and infrastructure needs and challenges confronting residents of the 37th Congressional District. A seat on the Committee gives the community a voice and a chance to fight for more investment in our regional infrastructure needs.

Congresswoman Richardson's Voting Record

111th Congress, 1st Session

Total Votes:	991
Votes Casted:	943
Votes Missed:	48
Vote Percentage	95%

111th Congress, 2nd Session

Total Votes:	514
Votes Casted:	495
Votes Missed:	19
Vote Percentage:	96.3%

111th Congress, Total

Total Votes:	1505
Votes Casted:	1438
Votes Missed:	67
Vote Percentage:	95.5%

Acquiring Federal Funding for the 37th Congressional District

Congresswoman Richardson has worked hard with House leadership to secure more than \$32 million in Federal Appropriations during her term in office. Though the current appropriations process is still underway, \$7.9 million of Congresswoman Richardson's requests for the 2011 budget year have been recommended by their applicable Appropriations Subcommittees. This is a promising first step for getting these appropriations approved and placed in the budget.

Fiscal Year 2011 Appropriations Subcommittee Recommendations

Commerce, Justice and Defense

Signal Hill Emergency Operations Center Communications System

\$400,000

City of Signal Hill

2175 Cherry Avenue, Signal Hill, CA 90755

The national significance of this project is that it will promote public safety and improve disaster response in one of our nation's major urban population centers. The EOC will enhance the regional ability to respond to an emergency or provide mutual aid after a natural disaster. The City of Signal Hill is located in the center of Long Beach and in close proximity to the Ports of Long Beach, Long Beach Airport and south bay area refineries. The Signal Hill EOC will provide a public safety resource in the Long Beach and Los Angeles region due to its centralized and high elevation vantage point to observe or carry out emergency response by local, state and federal emergency responders.

Defense

Bay Valley Institute

968 Palomares Ave., La Verne CA 91750

Self-Righting All Sensor Suite (S-RASS)

\$2,600,000

The purpose of this project is to assess capabilities of command, control, communication, computer, intelligence, surveillance, and reconnaissance and other technologies to increase the lethality and survivability of a small, modular military unit. The national significance of this project is that the ability to observe personnel and their activities and collect sensor data in a room, a pathway, on the roof and some of the difficult-to-access areas in day light, dim light or total darkness is pivotally important for Military Police and WMD Civil Support Teams. The ability to "watch" them and gain intelligence on their whereabouts, activities and intentions greatly enhances the ability to lock in on the specific

targets and quickly reduce the threat. Enhanced situational awareness results in reduced confrontation and less collateral damage thereby reducing the risk to our law enforcement and military personnel. Although studied in laboratories and used in overseas combat operations, this technology has not been employed by military police and WMD Civil Support Team venues because there has been insufficient tactics, techniques and procedures developed to allow for its use in Homeland Defense of the United States.

Women In Military Service For America Memorial Foundation

200 N Glebe Rd #400, Arlington, VA, 22203

Women In Military Service For America Memorial Foundation, Inc.

\$1,300,000

The purpose of this project is to help pay operating costs of the Women's Memorial as well as key operations of the Foundation. Included is maintenance of the world class archival collection of artifacts and memorabilia related to military women's service; staff costs for maintaining the register database of servicewomen, the heart of the Memorial; addition and refreshing of Memorial exhibits; conducting and digitizing oral histories; providing educational tours for school children and adult visitors; and providing a venue for military ceremonies and events. The national significance of this project is that funding requested will assure that the Women's Memorial remains open as a designated National Park Service "Safe Haven" in the event of a catastrophe in the District of Columbia or Northern Virginia and potential use by Homeland Security as a command post. It is an increasingly used site for Department of Defense promotion and retirement ceremonies as well as receptions after Arlington National Cemetery ceremonies. It is the site of meetings and conferences of various government agencies to include the Departments of Defense and Veteran Affairs and other federal and non-federal organizations. It is a place that provides a strong, positive message for young boys and girls. Over two million people have visited the Memorial; almost 150,000 in 2009. It sends a positive story about patriotism and the importance of military service.

Energy and Water

City of Long Beach

333 W Ocean Blvd

Long Beach, CA 90802

Long Beach Breakwater

\$600,000

The purpose of this project is to outline the feasibility of potential change in the East San Pedro Bay to improve water quality, the ecosystem and tourism while continuing to protect navigation, coastal zones and property. The national significance of this project is that it furthers the federal responsibility of restoring ecosystem, as well as improving recreation and water quality in the City of Long Beach.

Homeland Security

City of Compton

205 South Willowbrook Avenue

Compton, CA 90220

\$800,000

Enhanced Emergency Operations Center

The requested funding is needed to improve emergency management and preparedness capabilities in the City of Compton by constructing and maintaining a flexible, sustainable, secure, strategically located, and fully interoperable Emergency Operations Center (EOC) that will address and respond to identified deficiencies and needs in one of the nation's critical transportation hubs. When constructed and fully operational, the Compton EOC will be an essential element in the larger national emergency management system and will help ensure continuity of operations and continuity of government in major disasters or emergencies caused by any hazard, particularly any disaster or emergency involving the Alameda Corridor, the Ports of Long Beach and Los Angeles. The national significance of this project is that it will upgrade the ability of local government to protect infrastructure projects of national significance that are located in and near the City of Compton and to respond to public emergencies or disasters endangering the lives and property of persons living and working in one of the nation's major economic centers.

Transportation, HUD

Carson Redevelopment Agency

701 E. Carson Street

Carson, CA

90745

City of Carson, The Avalon Blvd Interchange Modification at I-405

\$1,000,000

This funding will be used to modify the configuration of the existing interchange of Avalon Boulevard at Interstate 405 (I-405) in the City of Carson. This project will add one additional Avalon Boulevard northbound lane by relocating the existing sidewalk behind the bridge columns. In addition the project includes the construction of a city collector roadway southwest of the interchange, reconfiguring the existing on- and off-ramps at Avalon Blvd. and constructing a new southbound on-ramp in the southeast quadrant of the interchange. When completed, the modification will allow access to the proposed 1.5 million square foot mall at a currently vacated site at the southwest quadrant of this interchange and create south bound 405 on-ramp from north bound Avalon Boulevard. The national significance is that the Avalon Blvd Interchange Modification at the I-405 is on one of the busiest highways in California and in the country, supporting both local traffic and truck traffic. Over 500,000 cars and trucks pass this interchange and/or use it a day. As a result of the traffic and environmental studies conducted for this development, it was concluded that interchange modifications at Avalon Boulevard –I-405 were necessary to provide improved

access to the mall as well as other land uses in the vicinity. The proposed expansion of California State University at Dominguez Hills, located approximately 2.5 Kilometer north of this interchange, will emphasize the need and benefit of this project.

City of Los Angeles/Watts Willowbrook

200 North Spring Street

Third Floor

Los Angeles, CA

90012

Watts DASH Community Circulator Bus Project

\$200,000

This funding will purchase three (3) DASH buses for community circulator service throughout the Watts community. DASH buses are neighborhood circulators, providing transportation to essential destinations for—in this community—low-income transit-dependent residents, disabled persons, students, seniors, as well as commuters (feeder service to regional Metro buses and trains). The national significance of this project is the feeding of the system into the larger regional transit system comprised of Metro buses, Metro trains and commuter trains. The project is part of the regional system to improve mobility, reduce congestion, and help toward attaining clean-air goals for the region. To non-transit users the project provides clean-air and traffic congestion relief benefits. This very important route carries nearly a million passengers per year.

Labor, HHS and Education

The Kellee Murchison-Bennett Women’s Heart Health Program

\$500,000

St. Mary’s Medical Center

1043 Elm Avenue

Long Beach, CA 90813

This project will provide for the expansion of the Kellee Murchison-Bennett Women's Heart Health Program in the Los Angeles and Long Beach region. The expansion effort will include a significant increase in outreach and educational efforts, screenings, follow-up testing, affordable medication, patient navigation services and specialist referrals to some 15,000 women in Long Beach who are at risk and under-served for heart disease. This innovative, comprehensive program will focus on providing these services to multi-ethnic, low-income, and under- or uninsured women in the local area through expanded outreach and education efforts and expanded outreach efforts via a new mobile clinic, and by way of referrals from local clinics and from within the St. Mary network.

St. Mary will evaluate the success of this program by producing data to show the number of clients reached through outreach efforts, thereby revealing the number of women and families educated on heart health, along with the number of women who receive specific health screenings and referral services. St. Mary is

particularly qualified to undertake this expansion as it has been rated in the top 10% in the nation for women's health. Through the expansion of The Kellee Murchison-Bennett Women's Heart Health Program, it will continue its commitment to improving women's health in Long Beach.

The national significance of this project is that it works to address and prevent heart disease in women, a disease that kills over 315,000 women per year in the United States, accounting for one in four of all deaths. According to a report from the Centers for Disease Control and Prevention, the gap between men and women's incidence of heart disease is quickly closing, with around the same number of men and women dying each year from it. In women the disease is often hidden, not presenting itself with the classic symptoms found in men. Of even more pressing urgency, middle-aged women now exhibit more of the risk factors for heart disease than middle-aged men. A large portion of these are low-income females in Los Angeles County and Long Beach that lack health education, health access, and the sociocultural motivation to prevent heart disease. This program expansion will make great strides towards eliminating those barriers.

Long Beach City College

\$500,000

Long Beach City College

4901 East Carson St.

Long Beach, CA 90808

This project will fund a significant expansion of the programs and training provided through LBCC's Advanced Transportation Technology & Energy Center's (ATTEC). These technology center classrooms will be used exclusively by students who are enrolled in Long Beach City College. LBCC's ATTE Center is one of ten Advanced Transportation Technology and Energy program sites in California created by the California Community College Chancellor's Office to keep California competitive as a national leader in advanced transportation and energy technologies. The ATTEC equips the local workforce with the skills needed in technology-driven transportation and energy industries, while improving the environment and stimulating the economy.

Fiscal Year 2010 Appropriations Successes

Energy and Water

Long Beach Desalination Research and Development Project
Harbor/South Bay Water Recycling Project, Los Angeles
Long Beach Breakwater Study

Labor – HHS – Education

Long Beach Memorial Medical Center, for equipment and facilities
City of Long Beach, for a Senior Services Collaboration Coordinator
Program

Commerce – Justice – Science

City of Long Beach – Youth Career Academy
City of Long Beach – Forensic Investigation Equipment

Transportation

City of Long Beach – Safety and Seismic Upgrades to the
Shoemaker Bridge

Defense

Women in Military Service for America Memorial
California State University Strategic Language Initiative

Total for Fiscal Year 2010: \$8,650,000

Fiscal Year 2009 Appropriations Successes

Commerce, Justice, Science

City of Signal Hill Police Department Interoperable Technology
Upgrade
Boys Town, Los Angeles Region
YWCA of Greater Los Angeles, for Sexual Assault Response Teams

Energy and Water

Long Beach Desalinization Project
Harbor / South Bay Water Recycling Project
Long Beach Water Reuse
Port of LA Harbor Main Channel Deepening

Financial Services

Cal State, Dominguez Hills Online Certificate Program for Veterans
and Disabled Students

Interior and the Environment

City of Compton Water Department, Water Resources Project

Fiscal Year 2009 Appropriations Successes (continued)

Labor, Health and Human Services and Education

Long Beach Memorial Medical Center, for equipment and medical facilities

WLCAC Reading Program for their shelter

St. Mary's Medical Center Foundation, for their Well Woman Outreach Program

LA County Community Development Commission Computer Literacy / Job Training Program for Public Housing Residents

Para Los Ninos, for teacher instruction and curriculum development

Defense

Quiet Drive Advanced Rotary Actuator

Integrated Medical Systems, Life Support for Trauma and Transport (LSTAT) Procurement

California State University Long Beach, Strategic Language Initiative

Integrated Medical Systems, Life Support for Trauma and Transport (LSTAT) R&D

Total for Fiscal Year 2009: \$18,149,000

Fiscal Year 2008 Appropriations Successes

Labor-HHS-Education Subcommittee

Compton CareerLink

Watts Labor Community Action Committee

YWCA of Greater Los Angeles

Center for Working Families, Long Beach

Transportation – HUD Subcommittee

Wattstar Theatre and Education Center

Energy and Water Subcommittee

Port of Long Beach Channel Deepening

Long Beach Water Reuse Project

Long Beach Desalination

Total for Fiscal Year 2008: \$5,873,000

111th Congress Committee and Sub-Committee Hearings

Congresswoman Richardson serves on the Homeland Security committee and on the Transportation and Infrastructure Committee. In her role as committee member, she sits on six Congressional subcommittees. These various bodies schedule a substantial number of hearings, briefings and site visits (often referred to as Field Hearings). As a member of the 111th Congress, she has attended over 140 committee activities. Some of the most important are listed below.

Committee on Homeland Security

Full Committee Hearings

- Feb. 25, 2009 “DHS: The Path Forward.”
- Mar. 4, 2009 “Examining 287(g): The Role of State and Local Law Enforcement in Immigration Law.”
- May 13, 2009 “The President’s FY 2010 Budget Request for the Department of Homeland Security.”
- Jun. 16, 2009 Hearing on H.R. 2868, the “Chemical Facility Anti-Terrorism Act of 2009.”
- Jul. 8, 2009 “FEMA Housing: An Examination of Current Problems and Innovative Solutions.”
- Jan. 20, 2010 “The United States Secret Service and Presidential Protection: An Examination of a System Failure.”
- Jan. 27, 2010 “Flight 253: Learning Lessons from an Averted Tragedy.”
- Feb. 25, 2010 “The President’s FY 2011 Budget Request for the Department of Homeland Security.”
- Mar. 25, 2010 “Visa Overstays: Can They be Eliminated?” Jun. 16, 2010 “Cybersecurity: DHS’ Role, Federal Efforts and National Policy.”

Briefings

- Mar. 31, 2009 Classified Member briefing on briefing on the border violence occurring along the U.S.-Mexican border.
- Apr. 29, 2009 Member briefing on Transportation Worker Identification Card (TWIC).
- Jul. 22, 2009 Member briefing on the Federal Protective Service’s ability to protect Federal facilities.
- Sep. 16, 2009 Classified Member briefing on the situation in Afghanistan to include a discussion of the assessment by General Stanley McChrystal and the Congressionally-mandated metrics of progress in Afghanistan required by section 1117 of Public Law 111-23. Briefing held for the Members of the Committee on Homeland Security and the Committee on Appropriations, the Committee on Armed Services, the Committee on Foreign Affairs, the Permanent Select Committee on Intelligence, and the Committee on the Judiciary received a Classified Member briefing on the situation in the Islamic Republic of Afghanistan. Oct. 1,

BRIEFINGS 2009 CONT...

- 2009—Classified Member briefing on current intelligence and threat streams relevant to the homeland.
- Jan. 13, 2010 Classified Member-Only briefing on the Flight 253 incident.
- Feb. 24, 2010 Classified Member-Only briefing on the November 9th shooting at Fort Hood, Texas.
- Apr. 28, 2010 Classified Member-Only briefing on processes and technologies at
- May 6, 2010 Classified Member-Only briefing on the May 1, 2010 attempted bombing in New York City. Joint with the Members of the House Leadership, the Committee on the Judiciary, the Committee on Homeland Security, the House Permanent Select Committee on Intelligence; the Committee on Appropriations Subcommittees on Commerce, Justice, Science; Homeland Security; Defense; and the Select Intelligence Oversight Panel.

Site Visits

- Jan. 7–8, 2010 Site Visit to United States Central Command (USCENTCOM) in Tampa, Florida and Naval Station Guantanamo Bay to examine current operations at Joint Task Force Guantanamo and assess the involvement of Department of Homeland Security equities.
- Jun. 21, 2010 Site Visit to New Orleans, Louisiana area to examine the homeland security and response issues associated with the *Deepwater Horizon* oil spill.

Subcommittee on Emergency Communications, Preparedness and Response

Hearings

- Mar. 3, 2009 “FEMA’s Gulf Coast Rebuilding Efforts: The Path Forward
- Jun. 9, 2009 “The FY 2010 Budget for the Federal Emergency Management Agency.”
- Oct. 1, 2009 “Preparedness: State of Citizen and Community Preparedness.”
- Oct. 27, 2009 “Preparedness: What has \$29 billion in homeland security grants bought and how do we know?”
- Jun. 29, 2010 “The Future of FEMA’s Grant Programs Directorate.”

Briefings

- Apr. 30, 2009 Member briefing on the Department of Homeland

HEARINGS 2009 CONT...

- Security's progress on the issue of interoperable emergency communications.
- Jul. 30, 2009 Member briefing on Hurricane Preparedness for the 2009 Hurricane Season.
- Oct. 7, 2009 Member briefing on public alerts and warnings.
- Feb. 26, 2010 Member briefing on the Federal Emergency Management Agency's community preparedness strategy.
- Jul. 14, 2010 Member Briefing on hurricane preparedness in the Gulf and the potential impacts of a hurricane on the Deepwater Horizon oil spill cleanup efforts.

Subcommittee on Intelligence, Information Sharing and Terrorism Risk Assessment

Hearings

- Jun. 24, 2009 "FY 2010 Budget for the Office of Intelligence and Analysis of the Department of Homeland Security."
(Portions of the hearing were conducted in Executive Session.)
- Nov. 19, 2009 "Reassessing the Evolving al-Qa`ida Threat to the Homeland."
- Mar. 17, 2010 "Working with Communities to Disrupt Terror Plots."

Briefings

- Feb. 26, 2009 Classified Member briefing on strategic operational planning for U.S. Government counterterrorism activities.
- Mar. 5, 2009 Joint Classified briefing with the Subcommittee on Emerging Threats, Cybersecurity, and Science and Technology on cybersecurity threats to United States Federal networks.
- May 27, 2010 Classified Member-Only briefing on current threat streams.

Committee on Transportation and Infrastructure

Full Committee Hearings

- 7/27/2010 Recovery Act: Progress Report for Transportation Infrastructure Investments
- 5/26/2010 Recovery Act: Progress Report for Infrastructure Investments
- 5/19/2010 [Deepwater Horizon: Oil Spill Prevention and Response Measures, and Natural Resource Impacts](#)
- 3/26/2010 [Recovery Act: Progress Report for Highway, Transit, and Wastewater Infrastructure Formula Investments](#)
- 2/23/2010 [Recovery Act: One-Year Progress Report for Transportation and Infrastructure Investments](#)
- 12/10/2009 [Recovery Act: Progress Report for Transportation Infrastructure Investment](#)
- 10/15/2009 [The Clean Water Act after 37 Years: Recommitting to the Protection of the Nation's Waters](#)
- 10/1/2009 [Recovery Act: 225-Day Progress Report for Transportation Infrastructure Investment](#)
- 7/31/2009 [Recovery Act: 160-Day Progress Report for Transportation and Infrastructure Programs](#)
- 6/25/2009 Recovery Act: 120-Day Progress Report for Transportation Programs
- 4/29/2009 [Recovery Act: 10-Week Progress Report for Transportation and Infrastructure Programs](#)
- 3/26/2009 [The Department of Transportation's Disadvantaged Business Enterprise Programs](#)

Subcommittee on Aviation

Hearings

- 7/14/2010 [Airline Fees](#)
- 6/16/2010 The Proposed United-Continental Merger: Possible Effects for Consumers and the Industry
- 2/24/2010 Aircraft Icing
- 2/4/2010 [Update: The Federal Aviation Administration's Call to Action on Airline Safety and Pilot Training](#)
- 1/27/2010 Reauthorization of the National Transportation Safety Board
- 12/2/2009 Commercial Space Transportation
- 9/23/2009 The Federal Aviation Administration's Call to Action on Airline Safety and Pilot Training
- 4/22/2009 Oversight of Helicopter Medical Services
- 3/18/2009 ATC Modernization and NextGen: Near-Term Achievable Goals
- 2/24/2009 US Airways Flight 1549 Accident
- 2/11/2009 FAA Reauthorization Act of 2009

Subcommittee on Coast Guard and Maritime Transportation

Hearings

- 7/20/2010 Status of U.S.-flagged Vessels in U.S.-Foreign Trade
- 3/11/2010 A Review of the Coast Guard Acquisition Programs and Policies
- 2/25/2010 FY 2011 Budget for the Coast Guard, the Maritime Administration, and the Federal Maritime Commission
- 9/30/2009 Review of the Coast Guard's Search and Rescue Mission
- 7/9/2009 The National Maritime Center and Mariner Credentials
- 5/20/2009 Piracy Against U.S.-Flagged Vessels: Lessons Learned
- 5/13/2009 FY 2010 Budget Requests of the Coast Guard, Maritime Administration, and Federal Maritime Commission
- 2/4/2009 International Piracy on the High Seas

Subcommittee on Highways and Transit

Hearings

- 7/21/2010 Oversight of the Highway Bridge Program and the National Bridge Inspection Program
- 6/30/2010 Utilization and Impacts of Automated Traffic Enforcement
- 5/5/2010 Assessing the Implementation and Impacts of the Clean Truck Programs at the Port of Los Angeles and the Port of Long Beach
- 4/14/2010 Using Innovative Financing to Deliver Highway and Transit Projects
- 12/8/2009 Public Transit Safety: Examining the Federal Role
- 10/29/2009 Addressing the Problem of Distracted Driving
- 7/16/2009 The Importance of Long-Term Surface Transportation Authorization in Sustaining Economic Recovery
- 4/28/2009 High Priority Project Program

Subcommittee on Railroads, Pipelines and Hazardous Materials

Hearings

- 6/30/2010 Utilization and Impacts of Automated Traffic Enforcement
- 5/5/2010 Assessing the Implementation and Impacts of the Clean Truck Programs at the Port of Los Angeles and the Port of Long Beach
- 4/14/2010 Using Innovative Financing to Deliver Highway and Transit Projects
- 7/16/2009 The Importance of Long-Term Surface Transportation Authorization in Sustaining Economic Recovery
- 4/28/2009 High Priority Project Program

Defense Authorization Act Conference Report Conferee

Congresswoman Richardson was appointed by Speaker Nancy Pelosi (CA-8) to the DOD Act conference committee, comprised of members from the House and Senate who are responsible for reconciling differences in the versions approved by each chamber. It is rare for a junior member to be selected for such a prestigious and important assignment, but Transportation and Infrastructure Chair **James Oberstar (MN-8) recommended Congresswoman Richardson be appointed a conferee because she has proven herself to be a hard worker who does her homework. Included in this Authorization Act was funding for the C-17, for which Congresswoman Richardson was able to fight for during the Conference.** In addition, Chairman Oberstar said “her intelligent and insightful questioning of witnesses has been a great asset at Committee hearings. I am pleased she was able to represent the Committee on Transportation and Infrastructure at this important conference.

The Conference Committee was instrumental in crafting the final 2010 National Defense Authorization Act (DOD Act). The DOD Act, which at \$679.8 billion is one of the most vital bills passed annually by Congress, authorizes troop levels, weapons systems, and sets policy and Congressional interest with respect to each branch of the armed services. After forceful and compelling floor statements by Congresswoman Richardson and others, the DOD Act was passed in the House by a vote of 281 to 146 on October 8, 2009. It was then passed by the Senate and signed into law by President Obama.

Recovery Act Funds for the 37th District

Carson

Magnolia Science Academy 3	Education	\$77,258
New Millennium Secondary	Education	\$51,883
Carson	Transportation	\$2,000,000
Peace & Joy Care Center	Public Safety	\$19,360
Magnolia Science Academy 3	Education	\$51,159
Carson, City of	Energy	\$929,900
Carson, City of	Housing	\$295,080
	Water and	
Majesty Construction, Inc.	Environment	\$946,159
California State University, Dominguez Hills	Education	\$111,107
California State University, Dominguez Hills	Science and Technology	\$330,000
California State University, Dominguez Hills	Science and Technology	\$150,677
City of Carson	Public Safety	\$295,680

\$5,258,263

Compton

Compton Community College	Education	\$232,702
Compton Unified	Education	\$10,909,224
Lifeline Education Charter	Education	\$103,147
International Medical Services for Health	Health and Human Services	\$138,520
Compton	Transportation	\$2,004,000
Compton	Transportation	\$583,592
Compton Unified	Education	\$191,792
Compton Unified	Education	\$10,527,936
Lifeline Education Charter	Education	\$80,413
Compton, City of	Energy	\$887,600
Compton, City of	Housing	\$848,514
Compton, City of	Housing	\$554,918
City of Compton	Public Safety	\$718,610
General Petroleum Corporation	Water and Environment	\$27,640
General Petroleum Corporation	Water and Environment	\$62,889
General Petroleum Corporation	Water and Environment	\$27,640
General Petroleum Corporation	Water and Environment	\$62,889

\$27,962,027

Long Beach

California United Terminals, Inc.	Water and Environment	\$260,000
Foss Maritime Company	Water and Environment	\$388,500
International Transportation Service, Inc.	Water and Environment	\$2,719,000
Metropolitan Stevedore Company	Water and Environment	\$80,750
SA Recycling LLC	Water and Environment	\$346,500
Ssa Terminals (long Beach), LLC	Water and Environment	\$213,500
Interval House	Housing	\$100,000
Hertz Equipment Rental Corp	Other	\$29,445
Hertz Equipment Rental Corp	Other	\$47,870
County of Los Angeles	Housing	\$318,945
City of Long Beach	Public Safety	\$1,464,816
Beyond Shelter	Housing	\$1,567,182
Catholic Charities of Los Angeles, Inc.	Housing	\$1,291,120
Banner, Adele M	Labor	\$1,800
Substance Abuse Foundation of	Labor	\$1,800
Substance Abuse Foundation of	Labor	\$1,800
Long Beach, City of	Public Safety	\$100,000
Long Beach, City of	Public Safety	\$7,779,081
Long Beach, City of	Water and Environment	\$4,008,250
Long Beach, City of	Health and Human Services	\$874,992
Ocean Associates, Inc.	Water and Environment	\$250,000
Los Angeles, City of	Public Safety	\$1,350,900
Disable Resources Center Inc	Health and Human Services	\$161,913
Titan Schools, Inc	Education	\$34,641
Hydrogen Energy California LLC	Energy	\$275,000,000
Interval House	Other	\$252,000
Long Beach Unified School District	Health and Human Services	\$1,169,362
Long Beach, City of	Energy	\$4,397,500
Children's Clinic 'Serving Children and their Families'	Health and Human Services	\$339,451
Long Beach, City of	Housing	\$2,332,444
Long Beach, City of	Water and Environment	\$2,856,000
Long Beach Community College District	Education	\$119,512
Total Terminals International LLC	Public Safety	\$1,000,000
International Transportation Service, Inc.	Public Safety	\$998,525
Southern California Institute for Research and Edu	Science and Technology	\$35,852
Long Beach Public Transportation Company	Transportation	\$16,497,214
Chugach McKinley, Inc.	Labor	\$4,740
California State University Long Beach Foundation	Science and Technology	\$179,982
Khmer Arts Academy	Other	\$50,000
Long Beach Opera	Other	\$50,000
Long Beach, City of	Health and Human Services	\$2,999,947
Alpha Star Corporation	Energy	\$457,007
Children's Clinic 'Serving Children and their Families'	Health and Human Services	\$892,285

Long Beach continued

California State University Long Beach Foundation	Science and Technology	\$74,913
California State University Long Beach Foundation	Science and Technology	\$721,589
Long Beach, City of	Water and Environment	\$452,212
ECO & Associates Inc	Water and Environment	\$92,977
Long Beach, City of	Housing	\$3,566,451
Manson Construction Co.	Water and Environment	\$2,450,000
International City Theatre Inc	Other	\$50,000
California State University Long Beach Foundation	Science and Technology	\$295,226
Community Development Institute Head Start	Health and Human Services	\$994,121
California State University, Long Beach	Education	\$242,526
Long Beach USD	Education	\$1,169,549
Long Beach USD	Education	\$16,376,314
Constellation Community Charter Middle	Education	\$51,437
Long Beach Unified	Education	\$28,001,663
Micro Enterprise Charter Academy	Education	\$28,694
New City	Education	\$84,862
Rosie the Riveter Charter High	Education	\$11,979
Long Beach Unified	Education	\$72,958
Long Beach City College	Energy	\$1,166,741
City of Long Beach	Water and Environment	\$539,634
City of Long Beach	Water and Environment	\$551,845
City of Long Beach	Water and Environment	\$4,319,107
City of Long Beach	Water and Environment	\$403,200
Long Beach	Transportation	\$310,099
Long Beach	Transportation	\$1,845,000
Long Beach	Transportation	\$683,368
Long Beach	Transportation	\$532,565
Long Beach	Transportation	\$240,657
Long Beach	Transportation	\$3,519,437
Long Beach	Transportation	\$4,154,260
Long Beach	Transportation	\$838,000
Long Beach	Transportation	\$1,865,000
Long Beach	Transportation	\$379,646
Long Beach	Transportation	\$885,985
Long Beach Unified	Education	\$524,994
City of Long Beach	Labor	\$7,786,909
Long Beach City College	Labor	\$762,505
Women Shelter of Long Beach	Public Safety	\$19,021
Interval House Crisis Shelter	Public Safety	\$21,217
Su Casa Ending Domestic Violence	Public Safety	\$21,217
Food Bank of Southern California	Health and Human Services	\$450,097
Clifford Beers Housing, Inc.	Housing	\$2,903,613
Long Beach Comm Improve League	Education	\$16,667

Long Beach Day Nursery, Inc	Education	\$15,379
Long Beach Community Services Development Corp.	Health and Human Services	\$1,640,313
Board of Trustees of the California State University	Education	\$716,500,000
Colegio New City	Education	\$12,501
Constellation Community Charter Middle	Education	\$63,010
Long Beach Community College	Education	\$517,662
Long Beach Unified	Education	\$31,731,984
Micro Enterprise Charter Academy	Education	\$18,317
New City	Education	\$176,690
Rosie the Riveter Charter High	Education	\$19,796
Long Beach USD	Education	\$591,880
California National Guard	Other	\$1,200,000
TOTAL:		\$1,174,990,413

Signal Hill

Signal Hill	Transportation	\$500,000
Signal Hill, City of	Public Safety	\$708,654
Gregg Drilling & Testing, Inc.	Water and Environment	\$32,854
City of Signal Hill	Public Safety	\$27,595
City of Signal Hill	Housing	\$35,893

\$1,304,995

District Totals

City	ARRA Funding	Population	Percentage of District Population
CARSON	\$5,258,263	93,955	13.9%
COMPTON	\$27,962,027	95,654	14.2%
LONG BEACH	\$1,174,990,413	474,014	70.3%
SIGNAL HILL	\$1,304,995	11,465	1.6%
37th District Total	\$1,209,515,698	675,088	100.0%

SAFE TEA-LU

SAFETEA-LU is a funding and authorization bill that governs United States federal surface transportation spending. It was signed into law by President George W. Bush on August 10, 2005 and expired as of September 30, 2009.

Since the time of expiration we have been operating under short term extensions while we endeavor to pass a larger bill, as described below. Because of funding shortfalls, we have had to come up with some creative means to transfer funds from the general fund into the highway trust fund to keep the program afloat.

The main barrier to passage is coming up with a funding mechanism. Because of how politically difficult it is at this time, the administration has NOT been supportive of moving forward before the mid-term elections. Every transportation expert essentially believes in the short term we have to raise the gas tax, amongst other revenue raisers, and in the long term we need to transition to a new means of funding (vehicle miles traveled most likely).

There is a glimmer of hope that we could get something passed in the lame duck, but it is far more likely that we would work on something at the start of next congress.

The committee has a draft out, but there has been no official bill introduced to reauthorize SAFETEA-LU in either the house or Senate.

Provides funding of \$450 billion over six years – the minimum amount needed to stop the decline in our surface transportation system, begin to make improvements, and restore and enhance the nation’s mobility and economic productivity. The Surface Transportation Authorization Act:

- Doubles the investment in highway and motor carrier safety to \$12.6 billion;
- Provides \$337.4 billion for highway construction investment, including at least \$100 billion for Capital Asset Investment to begin to restore the National Highway System (including the Interstate System) and the nation’s bridges to a state of good repair; and
- Provides \$87.6 billion from the Mass Transit Account of the Highway Trust Fund and \$12.2 billion from the General Fund for public transit investment to restore the nation’s public transit systems to a state of good repair, and provide access and transportation choices to all Americans from large cities to small towns.

Within this \$450 billion investment, the Act provides \$50 billion for Metropolitan Mobility and Access to unlock the congestion that chokes major metropolitan regions; and \$25 billion for Projects of National Significance to enhance U.S. global competitiveness by increasing the focus on goods movement and freight mobility.

In addition to this \$450 billion investment, the Act provides \$50 billion over six years to develop 11 authorized high-speed rail corridors linking major metropolitan regions in the United States. The high-speed rail initiative will provide greater consideration for projects that: encourage intermodal connectivity; produce energy, environmental, and other public benefits; create new jobs; and leverage contributions from state and private sources.

The \$450 billion for highway, highway safety, and transit investment over six years is a 38 percent increase above the current funding level (\$326 billion). The Surface Transportation Authorization Act also provides an additional \$50 billion investment for high-speed rail. Together, this \$500 billion investment will create or sustain approximately six million family-wage jobs.

In sum, the Surface Transportation Authorization Act of 2009 transforms the nation's surface transportation framework and provides the necessary investment to carry out this vision.

This increased investment is accompanied by greater transparency, accountability, oversight, and performance measures to ensure that taxpayer dollars are being spent effectively and in a manner that provides the maximum return on that investment.

*Legislation Introduced
by Congresswoman Laura Richardson*

H.R. 5472: The America RISING Act of 2010

This legislation will help rebuild our economy by establishing \$100 million grant program under the administration of the Secretary of Labor that would (1) pay salaries for two years for eligible college graduates to be hired by small businesses (2) establish a higher education opportunity program pursuant to which recent college graduates will receive funding to defray the cost of two years of additional education.

H.R. 5984: The CHEF Act: Will establish a pilot program to train prisoners in the culinary arts. This will provide them with marketable skill sets upon their release, help them get jobs, and lower their chance of recidivism.

H.R. 5988: The Cost Recovery Act: Will reduce the deficit by ensuring that federal user fees for services provided are set at an appropriate and equitable rate that accurately reflects the cost of the service.

H.R. 4897: Drivers Accelerated Interest Deductibility Act of 2010

This legislation will help increase the number of new automobiles purchased in the United States by making interest deductible on the purchase of new cars.

H.R. 4819: Expanding Opportunities for Older Americans Act of 2010

Reforms the community work programs in the Older Americans Act of 1965 by: (1) lowering the eligibility age, (2) eliminating requirement that spouse must be unemployed, (3) eliminating the cap on hours worked, (4) eliminating the requirement that the applicant be unemployed.

H.R. 4818: Not Too Small to Succeed in Business Act of 2010

Reforms and modernizes the SBA Section 8(a) Business Development Program to make it easier for small businesses in economically disadvantaged areas to secure SBA loans.

H.R. 4898: Elementary and Secondary School Emergency Preparedness Planning Act of 2010

This legislation empowers school districts in high-risk areas to bolster emergency preparedness training by establishing an emergency preparedness grant program.

Equal Rights for Health Care Act, H.R. 2744

Prohibits discrimination on the basis of sex, race, color, national origin, sexual orientation, gender identity, or disability status against any person in the United States under any health care service or research program.

H.R. 5562, the Homeland Security Grants Management Improvement Act

To amend the Homeland Security Act of 2002 to prohibit requiring the use of a specified percentage of grant under the Urban Area Security Initiative and State Homeland Security Grant Program for specific purposes, and for other purposes.

H. Res. 1474, Commending Harry Belafonte for receiving the Hubert H. Humphrey Civil and Human Rights Award from the Leadership Conference on Civil and Human Rights

Whereas Harry Belafonte received the Hubert H. Humphrey Award because---

- (1) He is as well-known for his pursuit of social justice as he is for his artistic talent;
- (2) His initiatives in overturning racial barriers throughout society are highly acclaimed;
- (3) He served as confidant to Dr. Martin Luther King, Jr., helped to organize the March on Washington in 1963, raised funds to free imprisoned civil rights protesters, and has been a powerful voice for voting rights;
- (4) As a result of his work as the driving force behind the 1985 'We Are The World' project, Mr. Belafonte was named a UNICEF Goodwill Ambassador in 1987;
- (5) He was an outspoken opponent of Apartheid and is known for his longstanding advocacy for the people of Haiti; and
- (6) He remains a tireless advocate of human rights efforts in the United States and throughout the world:

International Day for the Abolition of Slavery Resolution

Universal Children's Day Resolution

Philippines Independence Day Resolution, H. Con. Res. 153

Honoring the Aquarium of the Pacific Resolution, H. Res. 912

Legislation Pending Introduction by Congresswoman Laura Richardson

Foreign Vessel Amendment

It is drafted in a general form giving the President the ability to use foreign vessels in the time of an emergency. The President would decide when it would be triggered.

DERA Reauthorization (Clean Ports)

We will look to come up with a formula to reallocate DERA (the Diesel Emissions Reduction Act) on a fairer basis.

- Currently it is split evenly between every State and territory, but we will work on other formula ideas that may include:
 - Based on total state emissions
 - Based on truck vehicle miles traveled
 - Based on ton miles traveled
 - With a possible floor for each State/Territory

Goods Movement (Movement Act)

(1) Diesel Tax Bill: The bill would raise the diesel tax and take the delta and invest it into a goods movement trust fund. (2) Freight Planning: It would force greater planning at the federal level instead of the incorporation of regional plans.

Title VI Legislation

This bill would allow private actors to sue based on disparate impact under Title VI (a right they lost in the Sandoval Supreme Court case in 2002) as opposed to intentional discrimination.

Putative Registry Bill

The SMILE Dad Act, "Safeguarding a Mother's Identity and Lessening Exposure to the Father Act of 2010," will safeguard mother's identities and limit the exposure of father's during adoption proceedings. It would create a national registry so mother's who are giving up their biological children for adoption can have absent father's alerted during the process without publicly divulging either their or the father's identities. This bill also represents the first legislation Congresswoman Richardson has been able to work in conjunction with with Sen. Mary Landrieu, who is introducing its Senate counterpart.

The Communication and Alert Maintenance Program for Early Response (CAMPER) Act

Authorizes the Secretary of Homeland Security to establish a grant program to provide technical assistance and support to state parks and recreation departments to assist them in developing adequate emergency notification systems to provide adequate warning to persons (e.g., campers, hikers, fisherman) using public recreational lands.

Registry for Specials Needs Persons during Emergencies

Authorizes the Office of Disability Integration and Coordination along with appropriations to support staff and the continued maintenance of these positions.

The Oil Spill Prevention and Return to Yesterday (OSPREY) Act

The OSPREY Act identifies potential accidents and disasters, anticipates potential damages, prepares, implements, and re-inspects readiness tools, and includes academics in calculations.

- It provides that adequate information that is independently evaluated be prepared during each step.
- The information prepared for each task or step is used to build the next step.
- Sensitive natural resource areas are identified early to ensure that they are adequately protected during an oil spill and associated cleanup operations.
- The damage impact assessment will be thorough and accurate.
- Habitat restoration is the preferred method to mitigate the impacts to natural resources from an oil spill and associated cleanup activities.
- A detailed mitigation plan is to be prepared.
- The requirements for the mitigation plan are consistent with that required under other environmental legislation when impacts to natural resources are authorized.

- Adequate funding for the restoration activities will be provided and based on actual costs.
- The habitat restoration activities are to be completed successfully and in a timely manner.
- Penalties are to be provided that are strong enough that the responsible party will want to successfully prepare and implement the mitigation plan.
- Other mitigation methods will be allowed only if restoration is found to be technically infeasible.
- Independent oversight by federal oversight agencies, the scientific community, stakeholders, and the public is provided for all the document preparation and project implementation.
- Periodic updates of the documentation are required to account for new studies and technologies.

Key Votes in the 111th Congress

Congresswoman Richardson and the 111th Congress have made historic progress, working with President Obama, to take America in a New Direction. The Congresswoman is working closely with Congressional leaders to turn our economy around and create good jobs, make common sense reforms and targeted investments, and build consensus around reforming health insurance to ensure stability and security and launching a clean energy economy that makes California and America stronger. All these efforts are being tackled with fiscal discipline and accountability to the American people. Below is a list of key votes that the Congresswoman has supported:

ECONOMIC RECOVERY AND CREATING JOBS

ECONOMIC RECOVERY AND CREATING JOBS AMERICAN RECOVERY & REINVESTMENT ACT, enacted in the first month of President Obama's term, to jumpstart our economy, create and save 3.5 million jobs, give a tax cut to small business and 95% of American workers, begin to rebuild America's road, rail, and water infrastructure, and make a historic commitment to education, clean energy, and science and technology, with unprecedented accountability. (Signed into Law 2/17/09)

HIRE ACT, creating 300,000 jobs with tax incentives for businesses that hire unemployed Americans, unleashing billions of dollars to rebuild highways and infrastructure, strengthening small businesses with tax credits and accelerated write-offs, and cracking down on offshore accounts for the wealthy. (Signed into Law 3/18/10)

CASH FOR CLUNKERS, jump-starting the U.S. auto industry, providing consumers with up to \$4,500 to trade in an old vehicle for one with higher fuel efficiency—spurring the sale of 700,000 vehicles. (Signed into Law 8/7/09)

AMERICAN JOBS & CLOSING TAX LOOPHOLES ACT, to prevent corporations from shipping jobs overseas at U.S. taxpayer expense, make Wall Street billionaires pay their fair share of taxes, and promote American jobs by restoring credit to small businesses, extending tax incentives for American R&D and tax relief for middle class American families, rebuilding American infrastructure, and expanding summer jobs for young people. (Passed by House and Senate 7/22/10)

WORKER, HOMEOWNERSHIP & BUSINESS ASSISTANCE ACT, boosting the economy and creating jobs with more unemployment benefits for Americans hit by the recession, an expanded 1st-time homebuyer tax credit, and enhanced small business tax relief—expanded to all struggling U.S. businesses. (Signed into Law 11/6/09)

JOBS FOR MAIN STREET ACT, to boost small business, rebuild highways, and hire and retain teachers, police, and firefighters; paid for by redirecting TARP funds from Wall Street to Main Street. (Passed by House 12/16/09)

SMALL BUSINESS & INFRASTRUCTURE JOBS ACT, to extend Build America Bonds to help finance the rebuilding of schools, hospitals, roads and bridges; and target tax incentives to spur investment in small businesses and help entrepreneurs looking to start a new business. (Passed by House 3/24/10)

INNOVATION AGENDA, investing \$31 billion in science, technology, innovation, math education, cutting-edge research, advanced manufacturing technologies, and workforce training. (Signed into Law)

EDWARD M. KENNEDY SERVE AMERICA ACT, tripling volunteerism opportunities to 250,000 for national service for students to retirees; increased college financial awards. (Signed into Law 4/21/09)

LABOR-HHS-EDUCATION APPROPRIATIONS, providing targeted increases for health, education and worker training, including NIH research, Pell Grants, Head Start and clean energy jobs. (Signed into Law)

EDUCATION

STUDENT AID & FISCAL RESPONSIBILITY ACT, making the largest investment in college aid in history – increasing Pell Grants, making college loans more affordable, and strengthening community colleges – while reducing the federal deficit by ending wasteful student loan subsidies to banks. (Signed into Law 3/30/10)

AFFORDABLE QUALITY HEALTH CARE

AFFORDABLE QUALITY HEALTH CARE HEALTH INSURANCE REFORM, landmark legislation putting American families and small business owners—not the insurance companies—in control of their own health care; lowering costs for middle class and small business; holding insurance companies accountable to prevent denials of care and coverage, including for pre-existing conditions; strengthening Medicare and lowering prescription drug costs; creating up to 4 million jobs; and reducing deficit by largest amount in almost two decades. (Signed into law 3/30/10)

HEALTH CARE FOR 11 MILLION CHILDREN, to finally provide cost-effective health coverage for 4 million more children and preserve coverage for 7 million children already enrolled. (Signed into Law 2/4/09)

FDA REGULATION OF TOBACCO, granting the Food and Drug Administration authority to regulate advertising, marketing, and manufacturing of tobacco products, the #1 cause of preventable U.S. deaths, and to stop tobacco companies from targeting our children. (Signed into Law 6/22/09)

ENSURING SENIORS' ACCESS TO THEIR DOCTORS, by blocking scheduled 21% cut in Medicare physician payments through 2011 and updating payments by 2.2% in 2010 and 1.0% more in 2011. (Passed by House)*still need date*

FOOD SAFETY, to fundamentally change the way we protect our food supply; close gaps exposed by recent food-borne illness outbreaks; give the FDA new authorities. (Passed by House 7/30/09)

RYAN WHITE HIV/AIDS TREATMENT EXTENSION ACT, guaranteeing access to lifesaving medical services, primary care, and medications for low-income patients with AIDS and HIV. (Signed into Law 10/30/09)

CLEAN ENERGY JOBS & CONSERVATION

HOME STAR JOBS, to provide incentives for consumers to make their homes energy-efficient -- creating 168,000 jobs, cutting energy bills for 3 million families, and reducing our dangerous dependence on foreign oil and dirty fuels. (Passed by House 5/6/10)

AMERICA COMPETES REAUTHORIZATION, to invest in modernizing manufacturing; basic R&D; high risk/high reward clean energy research; and teaching science, technology, engineering and math. (Passed by House 5/28/10)

CLEAN ENERGY JOBS & CONSERVATION AMERICAN CLEAN ENERGY AND SECURITY ACT, historic legislation to create 1.7 million jobs (with the Recovery Act); help free us from funding terrorism with our dependence on foreign oil; reduce the carbon pollution causing climate change; keep costs low for Americans; will not increase the deficit. (Passed by House 6/26/09)

OMNIBUS PUBLIC LAND MANAGEMENT ACT, the most significant conservation bill in 15 years, strengthening tourism and rural economies with more than 2 million new acres of wilderness and parks. (Signed into Law 3/30/09)

FISCAL RESPONSIBILITY

FISCAL RESPONSIBILITY BUDGET BLUEPRINT, creating jobs with investments in health care, clean energy and education; cutting taxes for most Americans by \$1.5 trillion; cutting Bush deficit by more than half by 2013. (Action Completed) *still need date*

STATUTORY PAY-AS-YOU-GO, to restore 1990s law that turned record deficits into surpluses, by forcing tough choices; Congress must offset new policies that reduce revenues or expand entitlements. (Signed into Law 3/18/10)

PROTECTING CONSUMERS AND TAXPAYERS

HELPING FAMILIES SAVE THEIR HOMES ACT, building on the President's initiative to stem the foreclosure crisis, with significant incentives to lenders, servicers, and homeowners to modify loans. (Signed into Law 5/20/09)

PERMANENT ESTATE TAX RELIEF at the 2009 level to ensure that 99.8 percent of estates never pay a dime of taxes and offer certainty and stability for farmers and small businesses. (Passed by House 12/3/09)

PROTECTING CONSUMERS AND TAXPAYERS WALL STREET REFORM & CONSUMER PROTECTION ACT, common-sense financial regulatory reform to help prevent a crisis from happening again; to end taxpayer-funded bailouts and 'too big to fail' financial institutions; protect consumers from predatory lending and life savings from unnecessary risks; inject transparency and accountability into the financial system; and give shareholders a say on executive pay. (Passed by House and Senate 7/21/10)

CREDIT CARDHOLDERS' BILL OF RIGHTS, providing tough new protections already saving consumers money—like banning unfair rate hikes, abusive fees, and penalties—and strengthening enforcement. (Signed into Law 5/22/09)

FRAUD ENFORCEMENT & RECOVERY ACT, providing tools to prosecute mortgage scams and corporate fraud that contributed to financial crisis; creating an outside commission to examine its causes. (Signed into Law 5/20/09)

MORTGAGE REFORM & ANTI-PREDATORY LENDING ACT, to stop irresponsible loan practices behind the financial meltdown -- ensuring mortgage industry follows sound lending principles. (Passed by House 5/7/09)

LILLY LEDBETTER FAIR PAY ACT, restoring the rights of women and other workers to challenge unfair pay—to help close the wage gap where women earn 78 cents for every \$1 a man earns in America. (Signed into Law 1/29/09)

NATIONAL SECURITY/TROOPS AND VETERANS

DEFENSE PROCUREMENT REFORM, cracking down on Pentagon waste and cost overruns, which GAO says total \$296 billion just for 96 largest weapons systems, increasing oversight and competition. (Signed into Law 5/22/09)

NATIONAL SECURITY/TROOPS AND VETERANS FY 2009 SUPPLEMENTAL, meeting our troops' needs to wind down the Iraq war, change strategy in Afghanistan; make retroactive stop loss payments to 185,000+ service members; and expand New GI Bill to cover college education for all children of fallen U.S. service members since 9-11-01. (Signed into Law 6/24/09)

FY 2010 DEFENSE AUTHORIZATION, authorizing 3.4% troop pay raise, strengthening military readiness and military families support, focusing our strategy in Afghanistan and redeployment from Iraq. (Signed into Law 10/28/10)

FY 2011 DEFENSE AUTHORIZATION, to increase hostile fire and imminent danger pay and troop protection; extend TRICARE dependent coverage up to age 26; and strengthen counterterrorism. (Passed by House 5/28/10)

REPEAL OF DON'T ASK, DON'T TELL, to provide for the repeal of this outdated policy, contingent on the President, Defense Secretary, and Chairman of the Joint Chiefs of Staff certifying that the military review has been completed and that repeal would not impact military readiness. (Passed by House 5/27/10)

VETERANS HEALTH CARE BUDGET REFORM & TRANSPARENCY ACT, ensuring reliable and timely veterans health care funding by authorizing Congress to approve VA medical care a year in advance. (Signed into Law 10/22/09)

MILITARY CONSTRUCTION-VA APPROPRIATIONS, strengthening quality health care for 5 million veterans by investing 11% more for medical care, benefits claims processors, and facility improvements. (Signed into Law 12/16/09)

CAREGIVERS AND VETERANS OMNIBUS HEALTH SERVICES, landmark legislation providing help to family members and other caregivers of disabled, ill or injured veterans, while expanding and improving VA health care services for the nation's 1.8 million women veterans. (Signed into Law 5/5/10)

SECURITY FOR AMERICA'S COMMUNITIES HOMELAND SECURITY APPROPRIATIONS, strengthening security at our ports and borders and on commercial airlines, giving first responders tools to respond to terrorism. (Signed into Law 10/28/10)

SECURITY FOR AMERICA'S COMMUNITIES

AIRLINE PASSENGER CONSUMER PROTECTIONS & SAFETY, to require plans for long tarmac and flight delays, modernize air traffic control, and strengthen commercial pilot training requirements. (Passed by House 5/21/09)

HATE CRIMES PREVENTION ACT, giving law enforcement resources to prevent and prosecute hate crimes against Americans based on gender, sexual orientation, gender identity, or disability. (Signed into Law 4/29/09)

PUTTING 50,000 COPS ON THE BEAT, to authorize \$1.8 billion in COPS grants to put an additional 50,000 police officers on the street over the next five years. (Passed by House 4/23/09)

ENHANCING TRANSPORTATION SECURITY, to improve security for over 10 billion American mass transit trips each year – tripling resources for transit security. (Passed by House 6/4/09)

CHEMICAL & WATER SECURITY ACT, to increase security and safety of the nation's chemical plants and water facilities vulnerable to terrorist attacks and the millions of Americans that live nearby. (Passed by House 11/6/09)

District Deliverables



Stepping-up at Long Beach Airport

Congresswoman Laura Richardson, who sits on the Committee on Transportation and Infrastructure, introduced Deputy Secretary of Transportation John D. Porcari (3rd from the left) to 37th District first Transportation Roundtable to meet with 50 regional transportation stakeholders at the Hyatt Hotel in Long Beach on October 21, 2009.

Below, Rep. Richardson is joined by Long Beach Mayor Bob Foster (fourth from left), city officials and community members at the Colorado Lagoon groundbreaking ceremony in September 2009. Rep Richardson voted for the American Recovery and Reinvestment Act which provided \$3.2 million in federal stimulus money for the project that will improve water quality and lower pollution in the 13-acre urban wetland.



Telephone Town Halls

In the last year, Congresswoman Richardson has held four telephone town halls, not including the telephone town hall scheduled for August 2, 2010. Telephone town halls serve as a way for the Congresswoman to connect directly to the people she represents through what is essentially a large conference call. These town halls work by a call going out to phone numbers of residents of the 37th District, when someone answers the call they are directed on how to opt into the live forum if they wish to participate. An estimated 22,107 participated in our Telephone Town Halls to date. If they opt into the town hall event, they have the option of requesting to ask Congresswoman Richardson a live question during the town hall. The town hall and question and answer sessions are live.

- The first telephone town hall was held on March 9th and focused on jobs, job training and the economy. This town hall was sent out to 57,775 phone numbers in the district, with 3,880 (6.7 percent of the individuals called) spending some time listening to the telephone town hall event. Of those, 15 were able to ask Congresswoman Richardson a live question.
- The second telephone town hall was held on July 26th and was focused to the seniors of the district and on their needs and concerns. This town hall was sent out to 26,753 phone numbers in the district, with 3,007 (11.2 percent of the individuals called) spending some time participating in the telephone town hall event. Of those, 13 were able to ask Congresswoman Richardson a live question.
- The third telephone town hall was general in topic, ranging from recent legislation to services available to 37th District residents. This town hall was sent out to 97,639 phone numbers in the district, with 8,534 (8.7

percent of the individuals called) spending some time listening to the telephone town hall event. Of those, 13 were able to ask Congresswoman Richardson a live question.

- The fourth telephone town hall focused on issues important to women, who make up 50.9 percent of the population of the 37th District. This town hall was sent out to 64,558 phone numbers in the district, with 6,684 (10.4 percent of the individuals called) spending some time listening to the telephone town hall event. Of those, 10 were able to ask Congresswoman Richardson a live question. This town hall took place during live voting on the floor of the House of Representatives, which slightly decreased the number of questions the Congresswoman was able to answer.
- The fifth telephone town hall took place on August 2 and focused on issues important to parents and young adults. An estimated 5,789 residents of the 37th District were called and 10.3 percent of them participated in the telephone conference.

In The Community



Working Together Works

Rep. Richardson and her staff tours the PepsiCo of Carson, a world renown brand beverage company. Lower left, the Congresswoman celebrates the 25th Anniversary of neighboring Ken's Ice Cream Polar of Carson with owner Wanda Pope. Bottom right, Rep. Richardson is joined by Long Beach City Councilman Robert Garcia and community residents for the groundbreaking of a new Skatepark which opened on January 17, 2010 that received federal COBRA funds. The 8,000 square foot hybrid skatepark consist of TrueRide ramp and pre-cast Spohncrete features.



Senior Briefing



From the time Congresswoman Laura Richardson was elected as a member of the U.S. House of Representatives in 2007, the annual 37th District Senior Briefing has grown by leaps and bounds. The event galvanizes seniors in the district, providing transportation for them to join with other seniors from Carson, Compton, Long Beach, Signal Hill and Watts. Each senior is treated to a four-hour event that includes a full course lunch, information on good and services which includes but is not limited to health screenings, eye exams and nutritional tips. Seniors represent 11.1 percent of the 37th District. Our recent Senior Briefing in 2010 attracted a record 1,020 senior women and men, 350 of them were residents of Long Beach.



Art Competition



Halle Core of Long Beach 2009 Winner

Displaying Their Artistic Best

Each spring, the Members of the U.S. House of Representatives sponsor a nationwide high school art competition. The Congressional District Art Competition offers students in the 37th District an opportunity to be recognized and encourage their artistic talent. The winning entrant from each congressional district is displayed in the U.S. Capitol for one year. This year's annual event was held on May 10th at Cal State University Dominguez. Top, 2009 Arts Competition winner Halle Core of Long Beach (2nd from left) is shown with her parents and (4th from left Rep. Richardson) and competition judge David Brown. Right, 2010 Arts Competition winner Terrell Brim (center) is joined by Rep. Richardson and his mother at the U.S. Capitol.



2010 Winner

Leading Beyond the 37th Congressional District



Addressing Gulf Coast Oil Spill and War in Iraq

A tireless worker, Congresswoman Laura Richardson addresses the media at the site of the worst oil spill in American history in New Orleans.

Right, Rep. Richardson is shown in Iraq where she met with troops and military officials concerning the Iraq War .



Supporting Samoan Constituents of 37th Congressional District by coordinating aid for American Samoa

Taking The Lead

Congresswoman Laura Richardson took the lead on Samoan Disaster Relief, after the devastating tsunami hit the American Island of Samoa on September 29, 2009. Rep. Richardson was instrumental in securing an aircraft that airlifted 90,000 pounds of supplies from the 37th District community volunteers to American Samoa. Top right, Rep. Richardson is joined at the Long Beach Airport by Congresswoman Eni Faleomavega on October 22, 2009. Bottom left Rep. Richardson visited the Samoan Congregational Community Church in Carson, and with Chief Pele of the Samoan Disaster relief Coalition.



NEXT STEPS

I. CALIFORNIA DISTRICT OFFICE

- 1) Continue to bring needed resources to the district
- 2) Continue to increase awareness of casework support
- 3) Continue casework positive resolutions
- 4) Open a satellite office in the Watts Willowbrook area
- 5) Launch “People’s Congress”
- 6) Conduct Community Workshops
 - Veterans
 - Small Business
 - Immigration
 - Employment / Job Training
 - Military Academy Nominations
- 7) Expand use of new media and district outreach
- 8) Continue to increase the districts visibility with high profile guests for awareness and resource support

NEXT STEPS

II. WASHINGTON, D.C. CAPITOL OFFICE

- 1) Move forward major nationwide transportation legislation pertinent to the District
 - National Freight Policy
 - National Clean Trucks Program
 - Fairer Allocation of Harbor Maintenance Tax (HMT)
 - Progress with high speed rail in California
- 2) Continue to obtain funding
 - Safe-Tea-Lu Reauthorization
 - Appropriations
 - Water Resources Act (WRDA)
- 3) Continue to garner the respect of my colleagues, industries and leadership
- 4) Maximize work opportunities as Sub-Committee Chair of Emergency, Communications, Preparedness and Response
 - Support a nationwide implementation plan for “Continuity of Government”
 - Support a nationwide alert system (hurricanes, floods, etc.)
 - Support a nationwide interoperable public safety system
 - Support a nationwide policy and implementation for cargo inspection
 - Support regional staff and plans for disability coordinators
- 5) Continue to build on 111th Congress introduced legislation
 - Expand SBA Section 8a
 - Expand Older American’s Opportunity Act
 - Reinstate deductible vehicle sales tax